

SGT Type Weld in Sightglass DIN8902



Applications: The compact design of this unit makes it ideal for inspection use in small bio-reactor vessels and the lids of Manways or inspection hatches. Used widely in the food, dairy, beverage, cosmetic and pharmaceutical industries.

Operating conditions: These units are available for pressures up to 10 Bar (depending on size, higher pressure ratings are available on request)

Parts list:

1. Welding male (1.43041/1.4404 material)
2. Nut (1.4301 material)
3. Gasket (Silicone, maximum temperature 200°C)
4. Sight glass disk (Borosilicate, maximum temperature 260°C)

Working pressure 10 Bar

Certificates: EN10204.3.1 certificate

Subject to modification without notice in advance

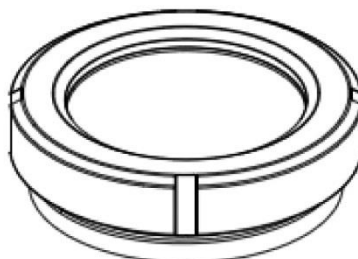
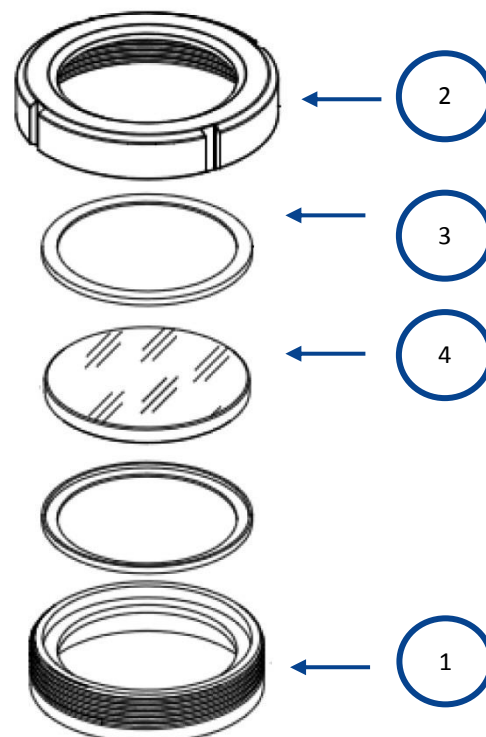

Product Datasheet

CODE	D1	D2	SG	D	H	P.R
All measurements are in MM						
SGT50DPB/89	50	80 X 3	64.5 X 10	92	35	10
SGT65DPB/89	65	95 X 3	85 X 10	108	39	10
SGT80DPB/89	80	114 X 3	100 X 10	125	42	10
SGT100DPB/89	100	130 X 5	115 X 10	146	45	10
SGT150DPB/89	150	180 X 5	165 X 10	208	45	10

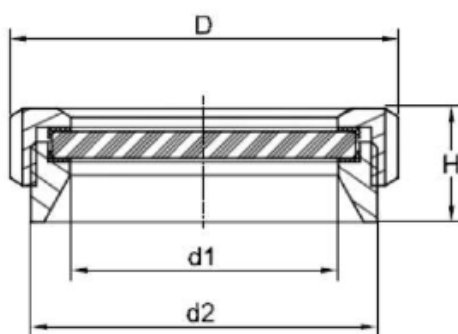
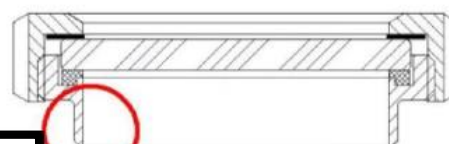
**Standard type design:**

Standard straight edged design is a liquid trap when sight-glass is fitted to the side of a vessel.

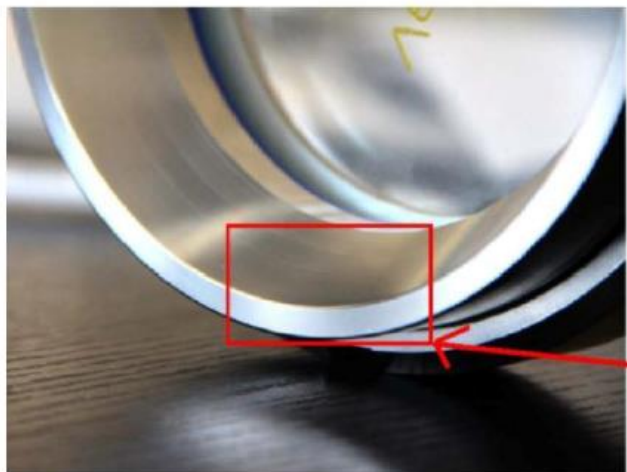
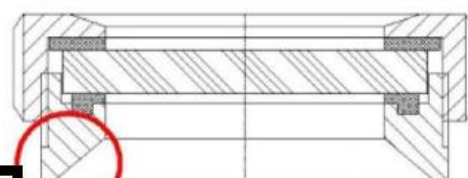
**Versaline type design:**

The Versaline design eliminates the possibility of trapped liquid due to its self-draining capability.

This Data Sheet refers to the material as supplied. The information contained herein is given in good faith, but no liability will be accepted by the Company in relation to same. We reserve the right to change the details given on this Data Sheet as additional information is acquired. Customers requiring the latest version of this Data Sheet should contact our sales department.

Unit N2, Gildersome Spur, Gildersome, Leeds, LS27 7JZ | Tel: 0113 252 6712 | Email: info@manways.co.uk | www.manways.co.uk